

Schematics - Main PWB

Top Level

Version 7.1, edit 5

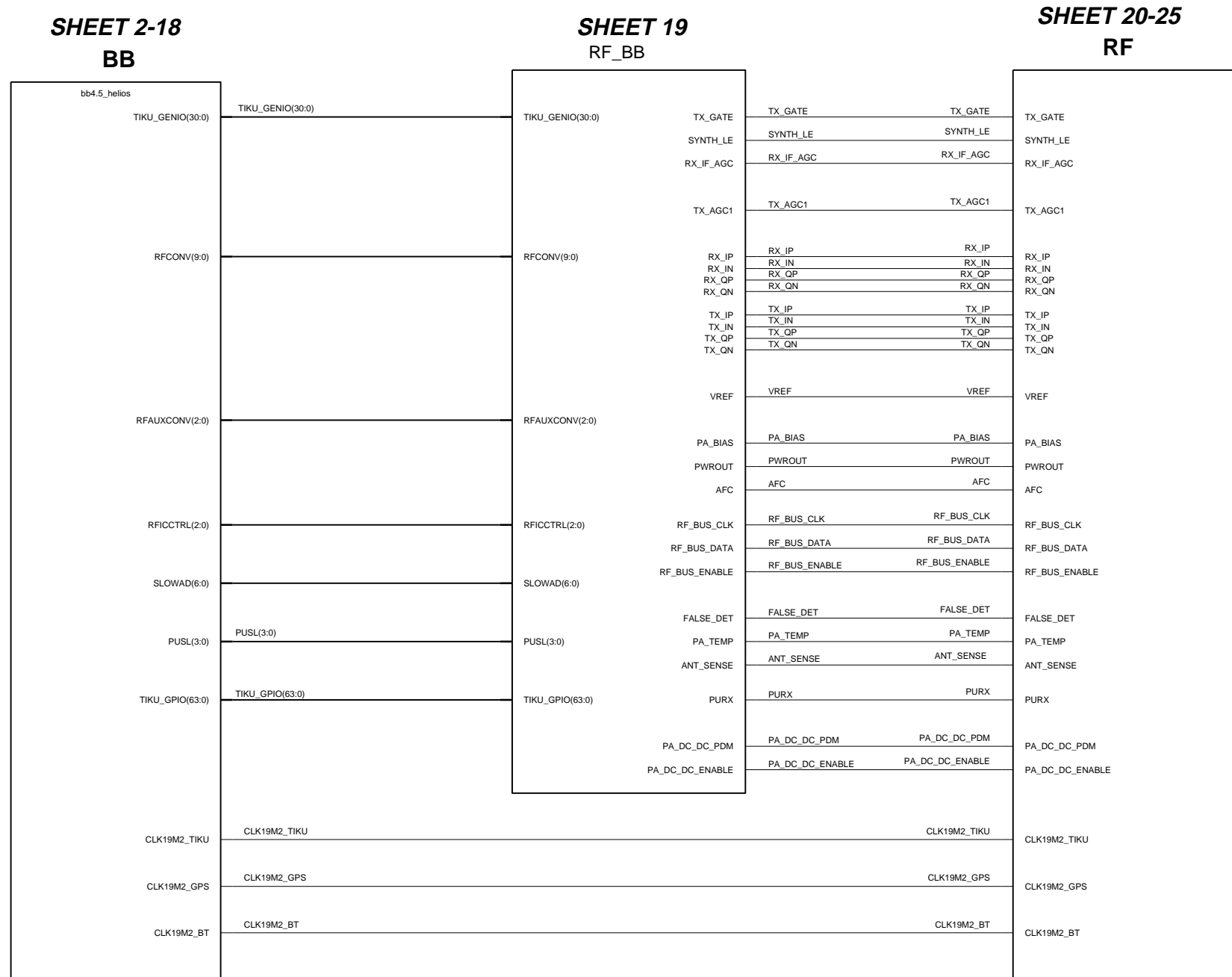

Baseband - Top Level

Version 7.1, edit 5

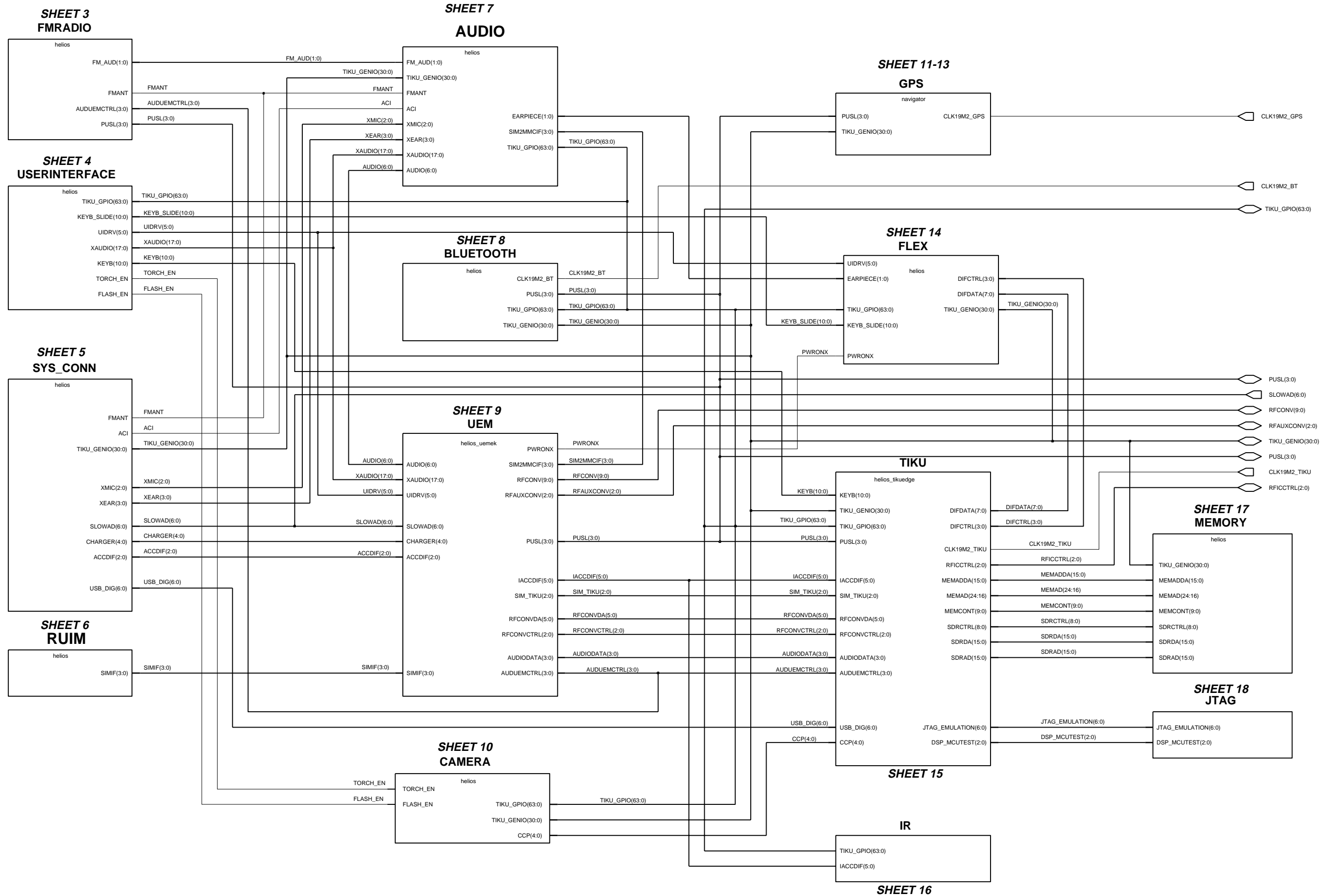

Front End

Version 7.1, edit 5

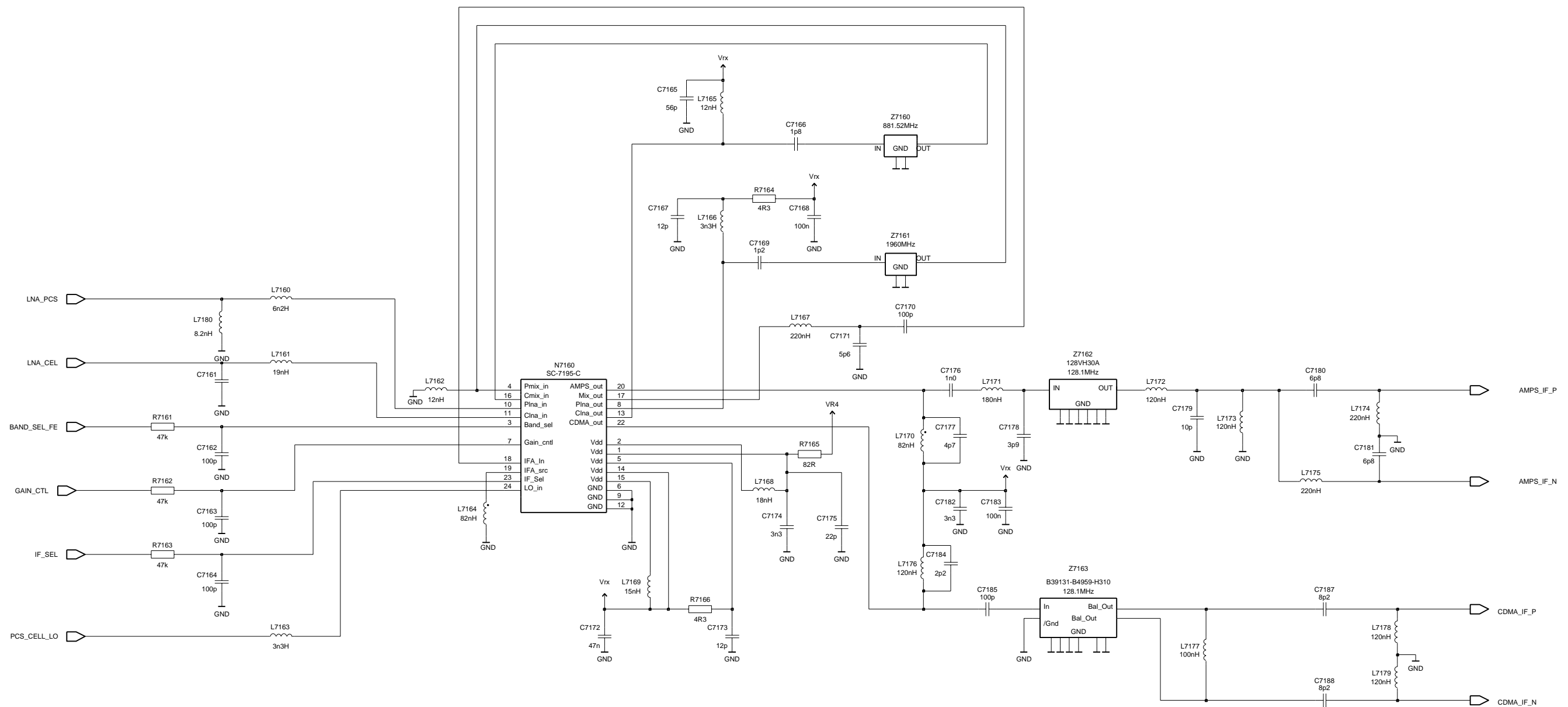

MODES	LOGIC INPUTS		
	BAND	GAIN_CTL	IF_SEL
CEL CDMA Hi Gain	0	1	0
CEL CDMA Lo Gain	0	0	0
PCS CDMA Hi Gain	1	1	0
PCS CDMA Lo Gain	1	0	0
AMPS Hi Gain	0	1	1
AMPS Lo Gain	0	0	1

Audio

Version 7.1, edit 5

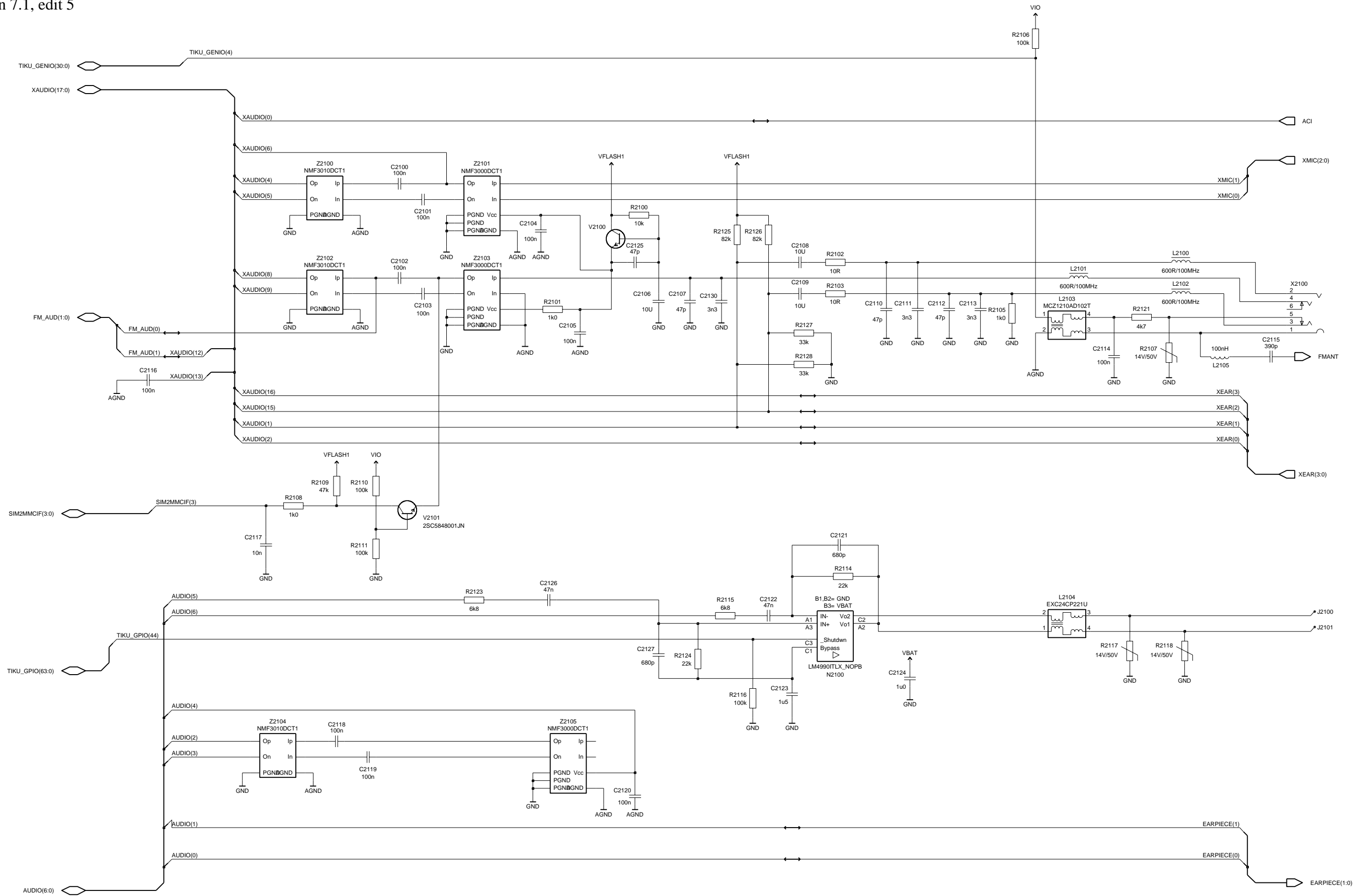

UI

Version 7.1, edit 5

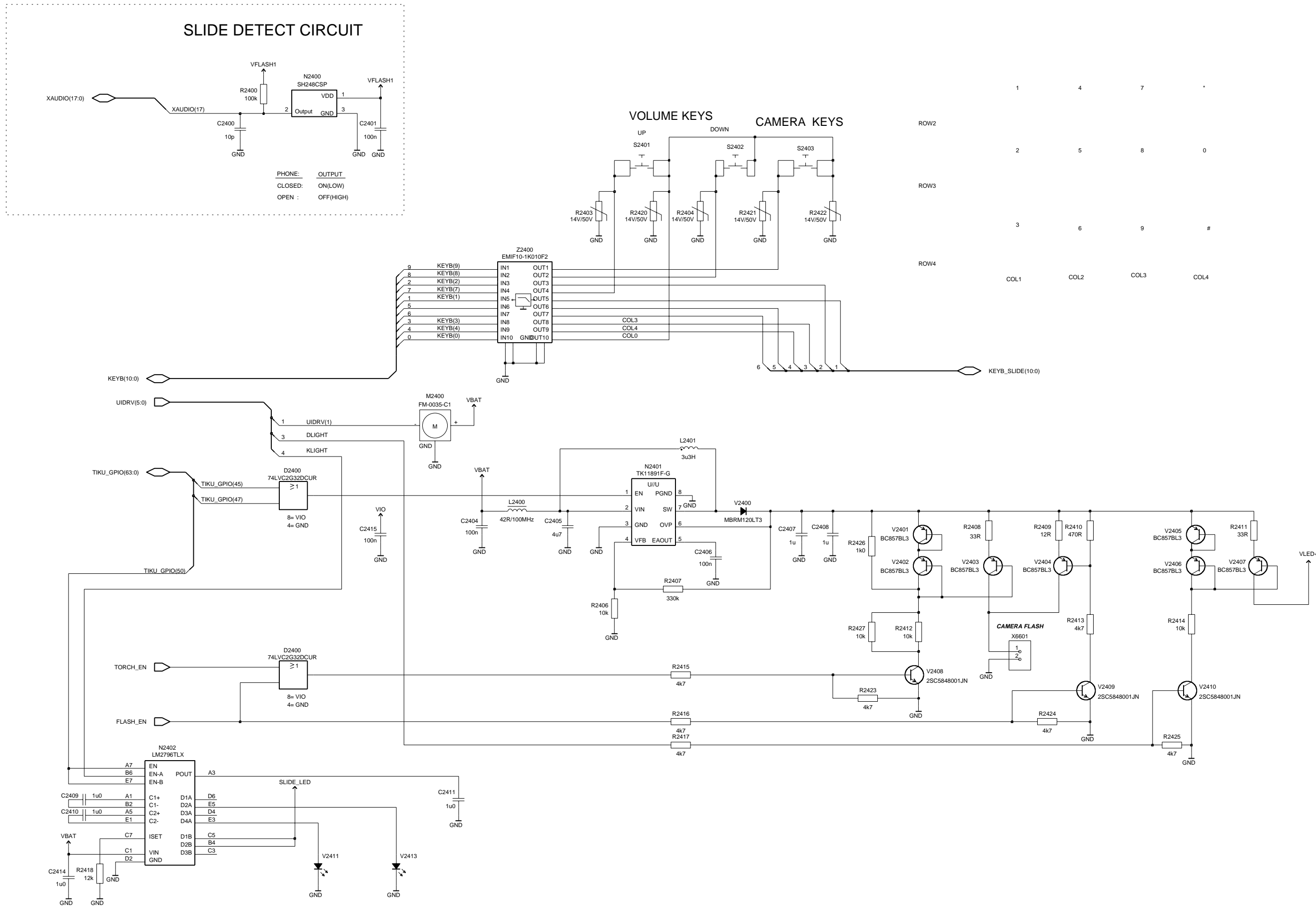

Memory

Version 7.1, edit 5

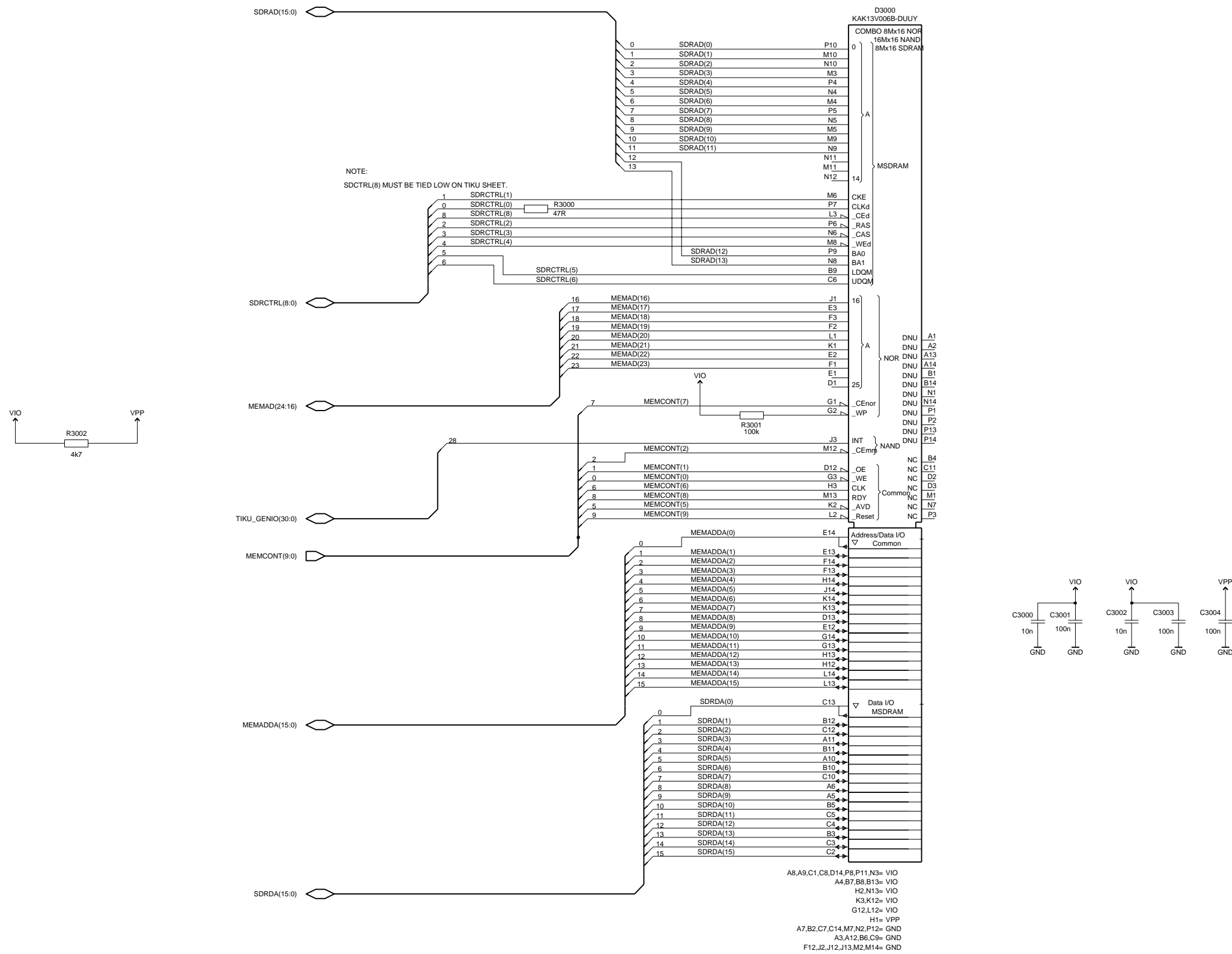

PA

Version 7.1, edit 6

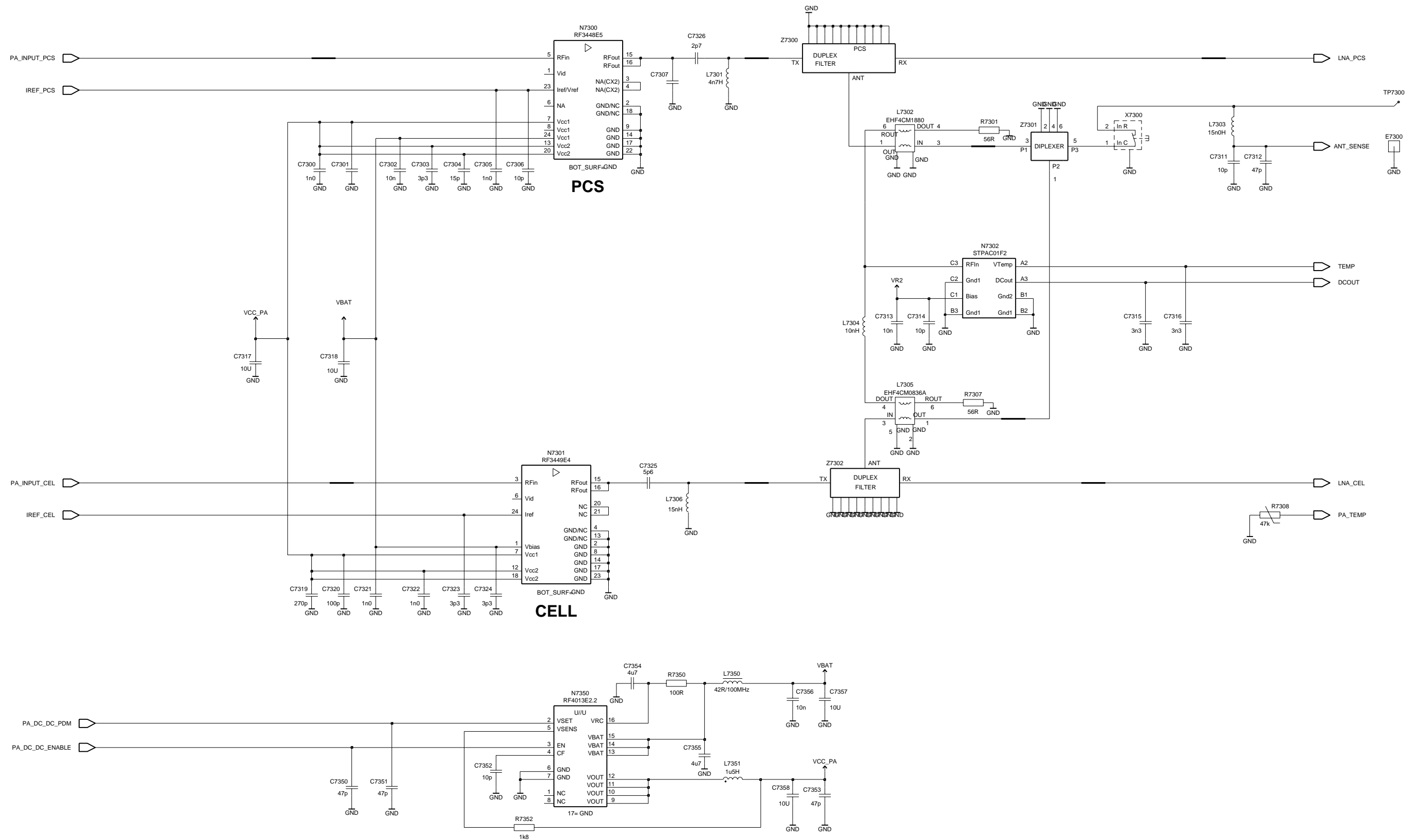

RF-BB Interface

Version 7.1, edit 5

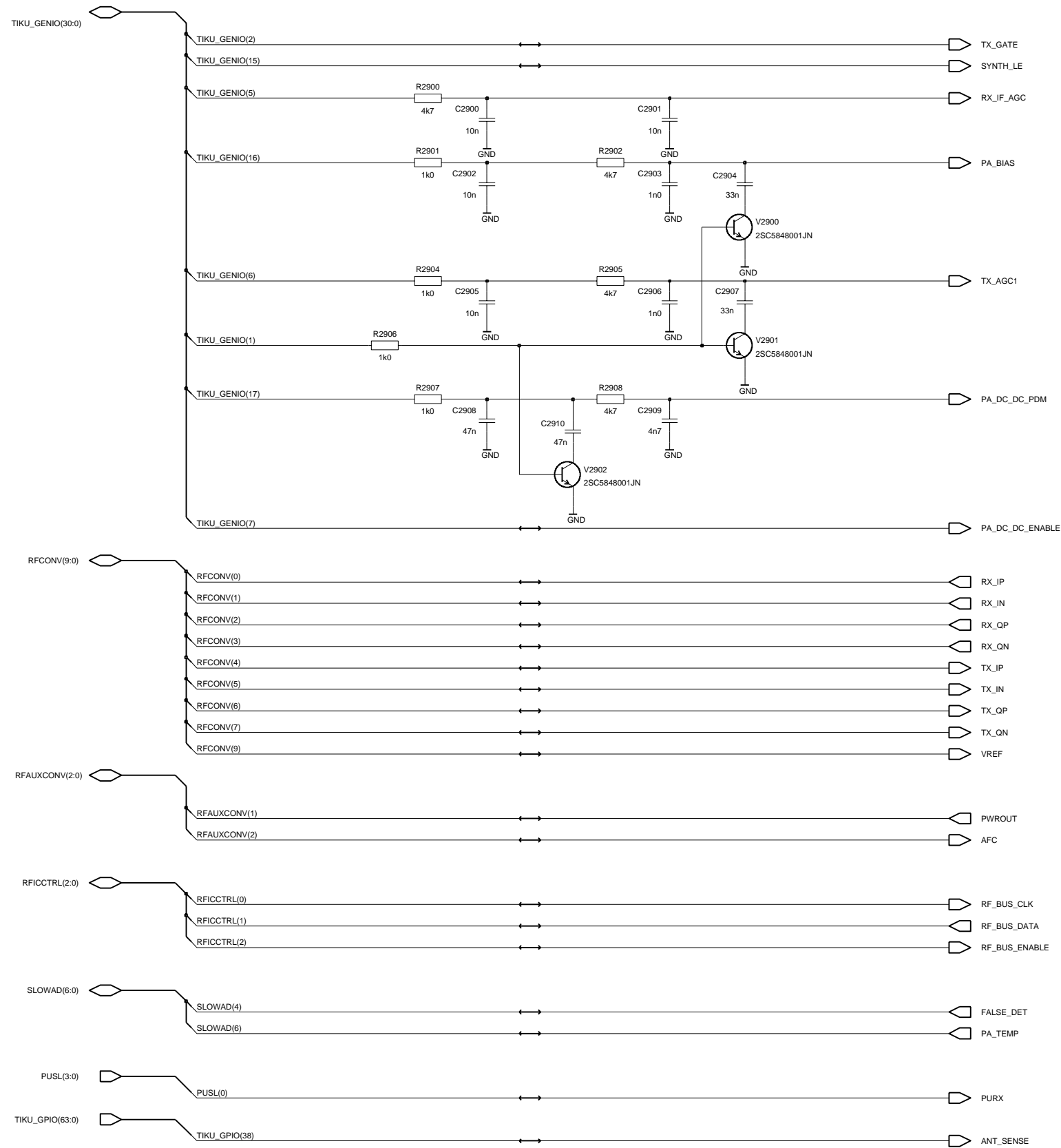

RF - Top

Version 7.1, edit 5

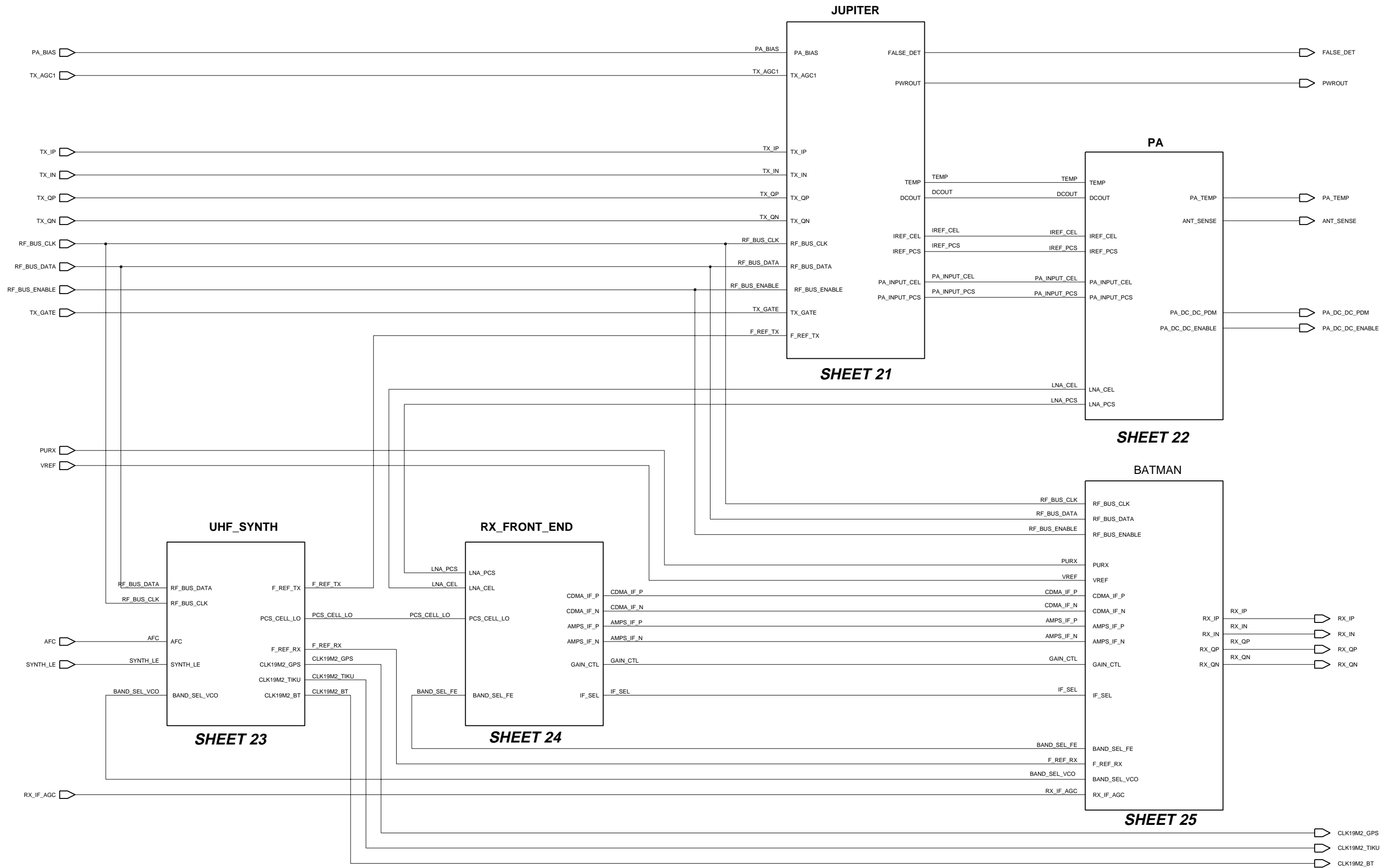

UIM Connector

Version 7.1, edit 5

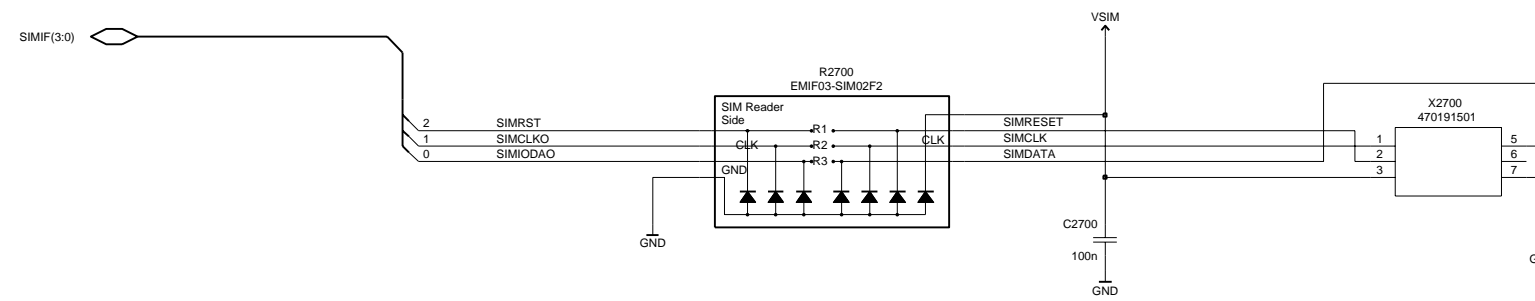

NOTE:

MECHANICS NEED TO PROVIDE EMI SHIELDING FOR SIM CARD.

PLACE R2700 CLOSE TO PINS.

KEEP SIMDATA TRACE SHORT.

System Connector

Version 7.1, edit 5

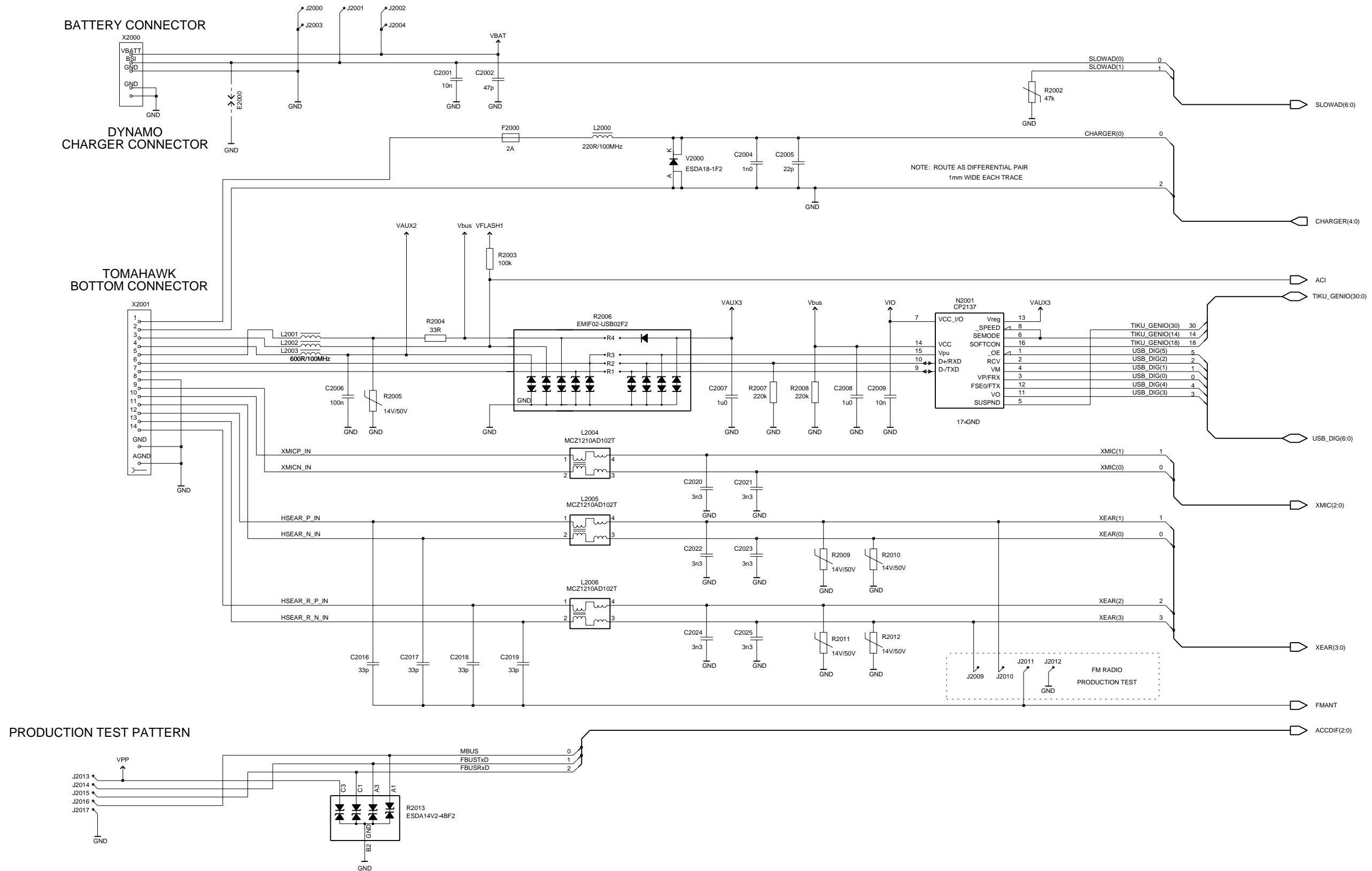

UHF Synthesizer

Version 7.1, edit 5

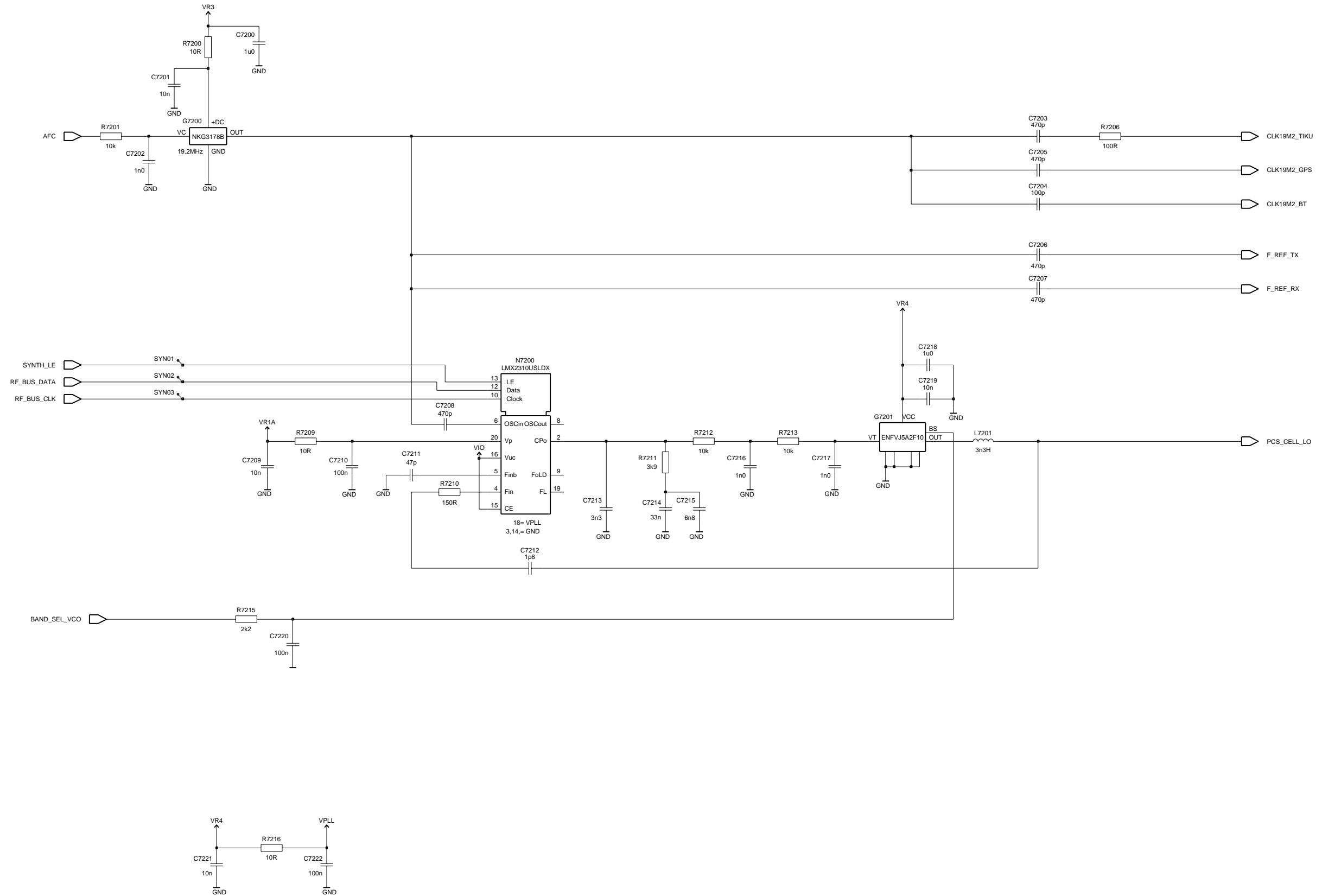

UEME

Version 7.1, edit 5

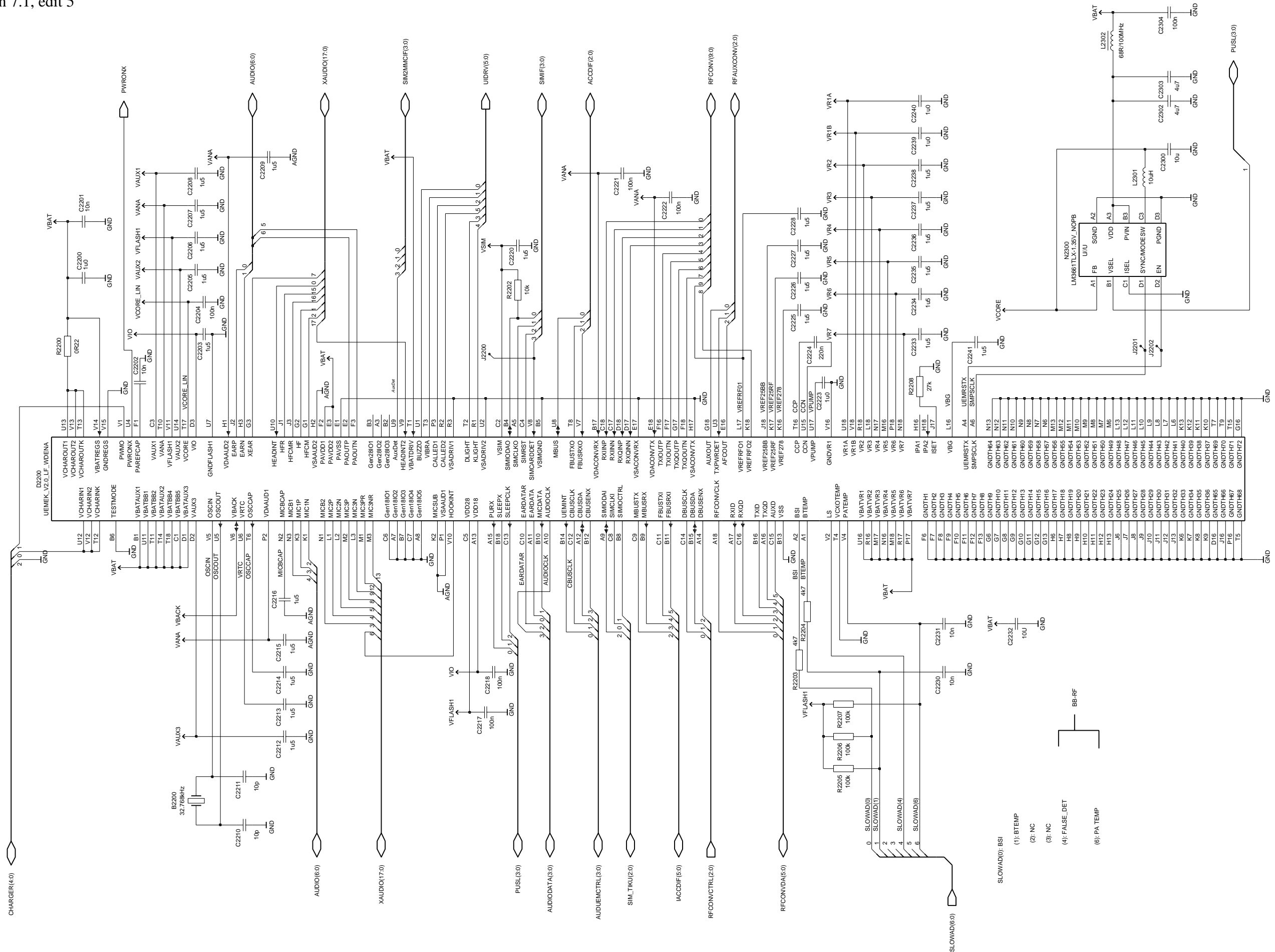

- SLOWAD(0): BSI
 (1): BTEMP
 (2): NC
 (3): NC
 (4): FALSE_DET
 (6): PA_TEMP

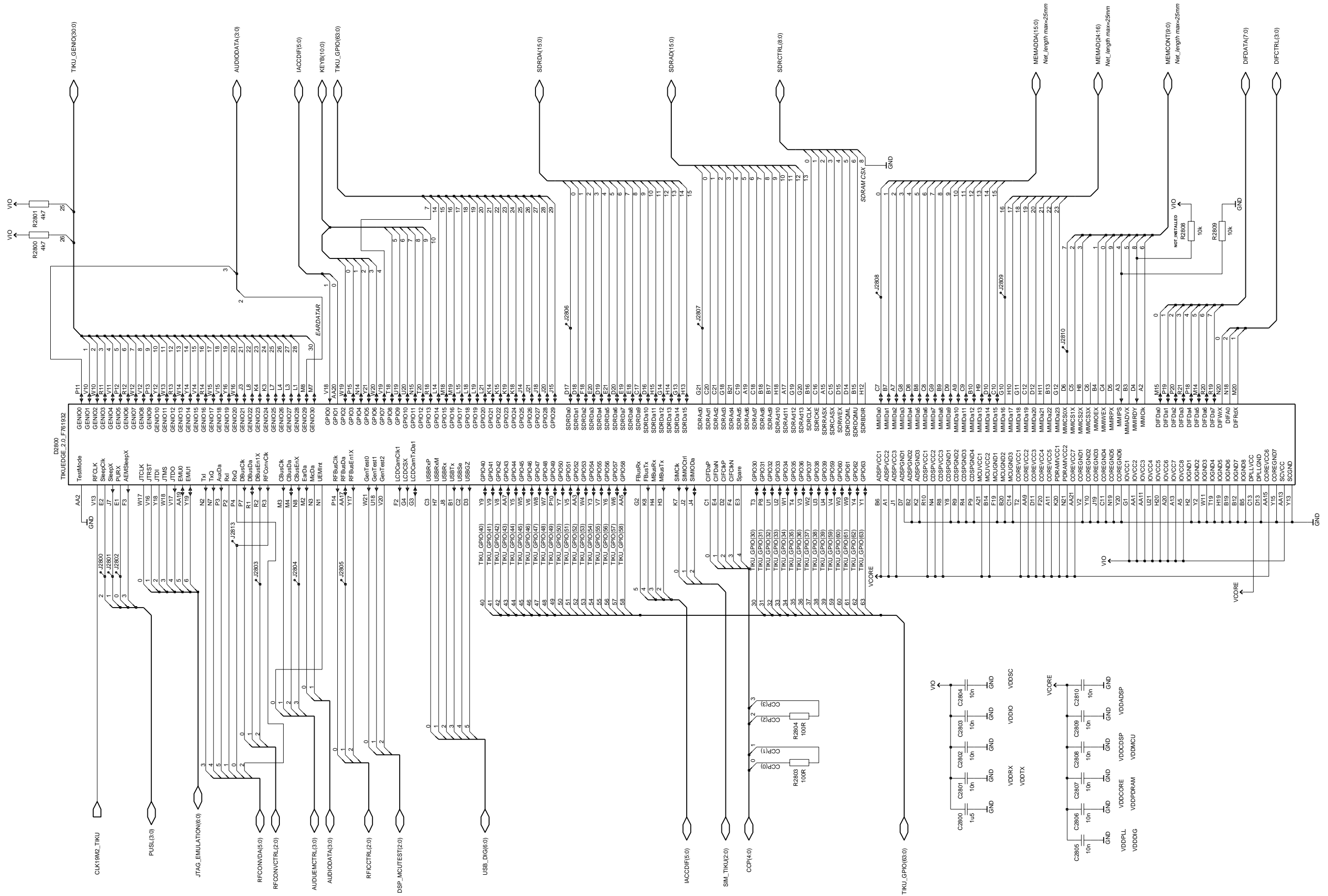

Rx

Version 7.1, edit 5

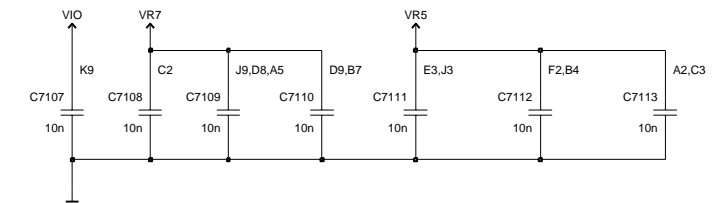
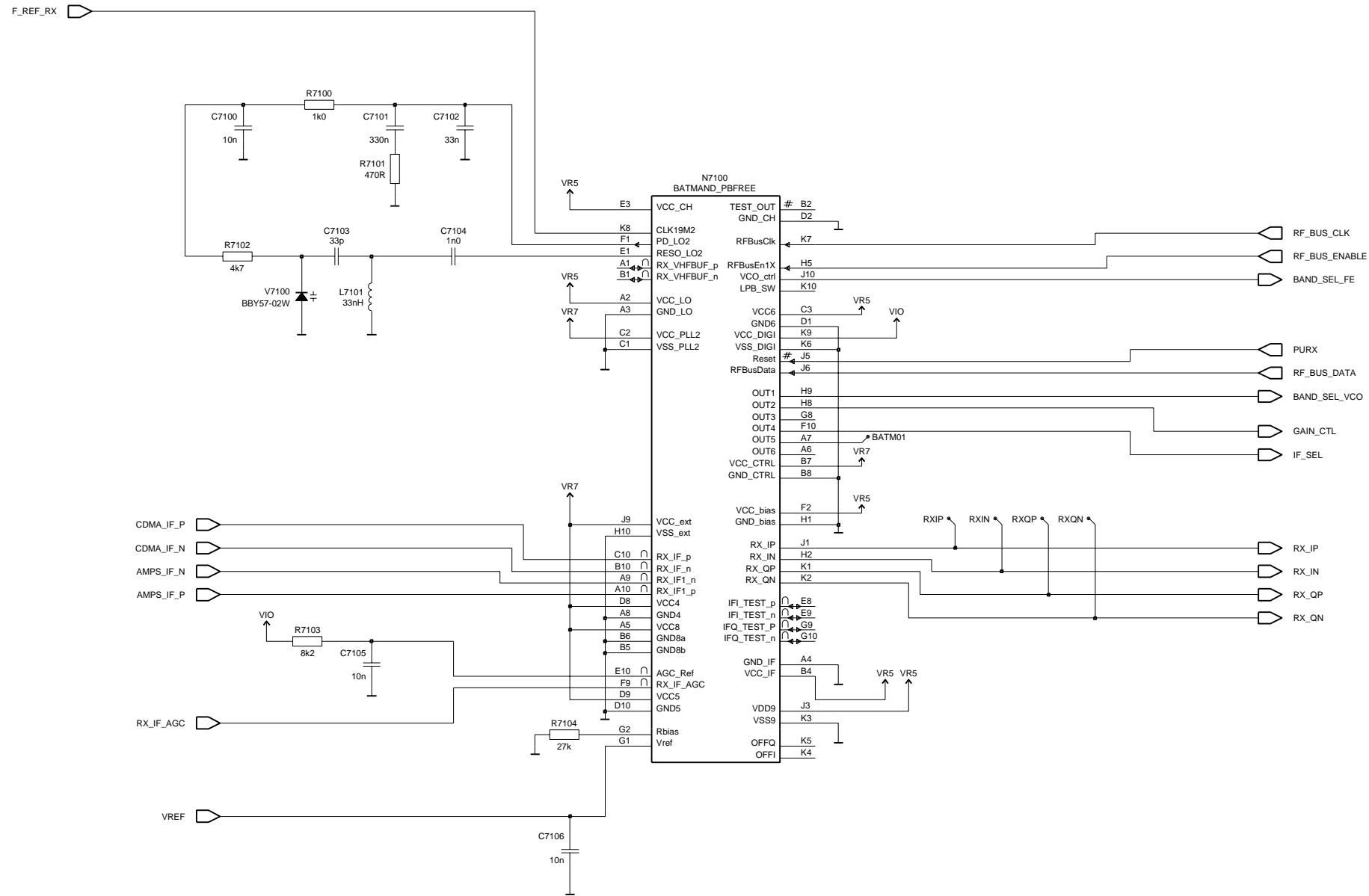

Tx

Version 7.1, edit 5

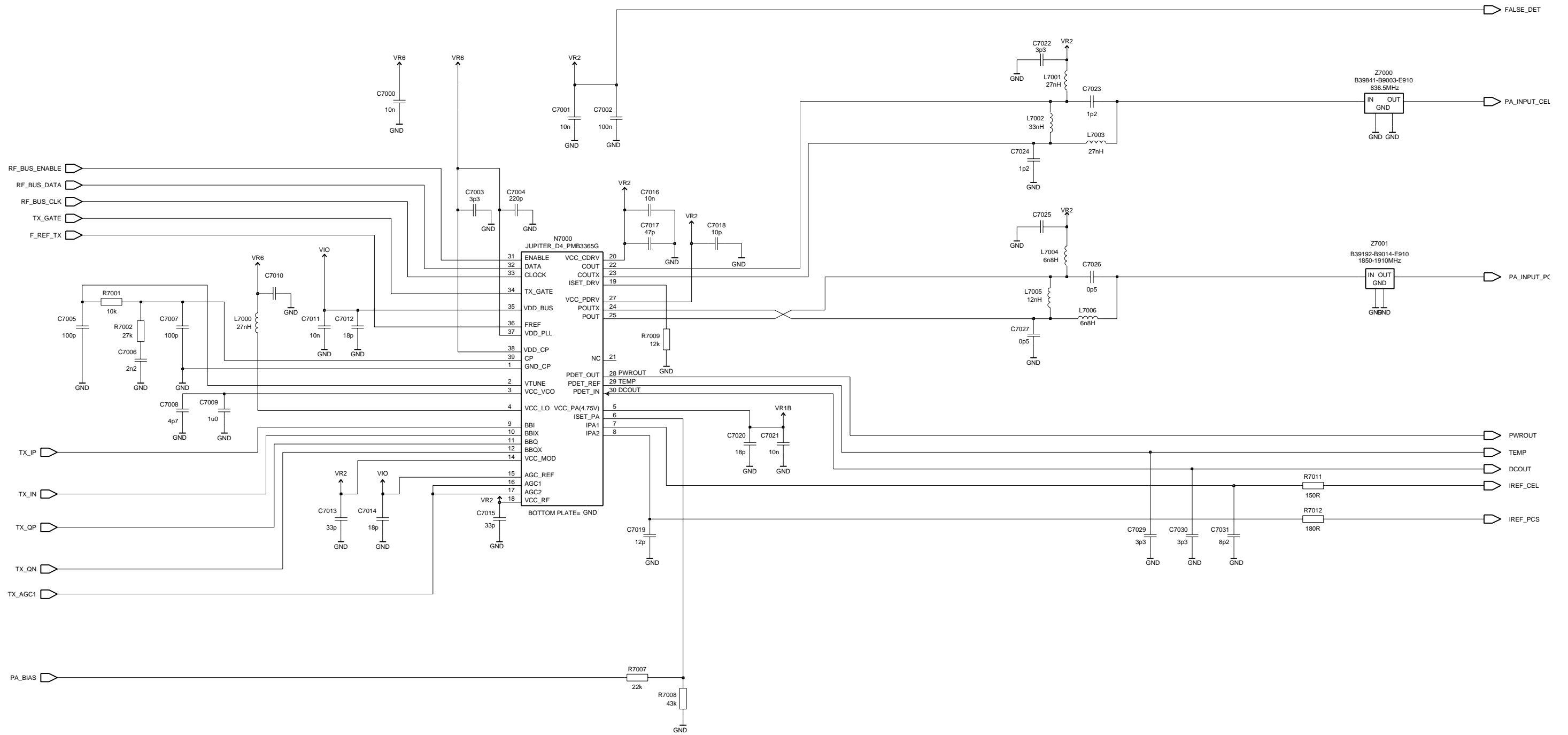

FM Radio

Version 7.1, edit 5

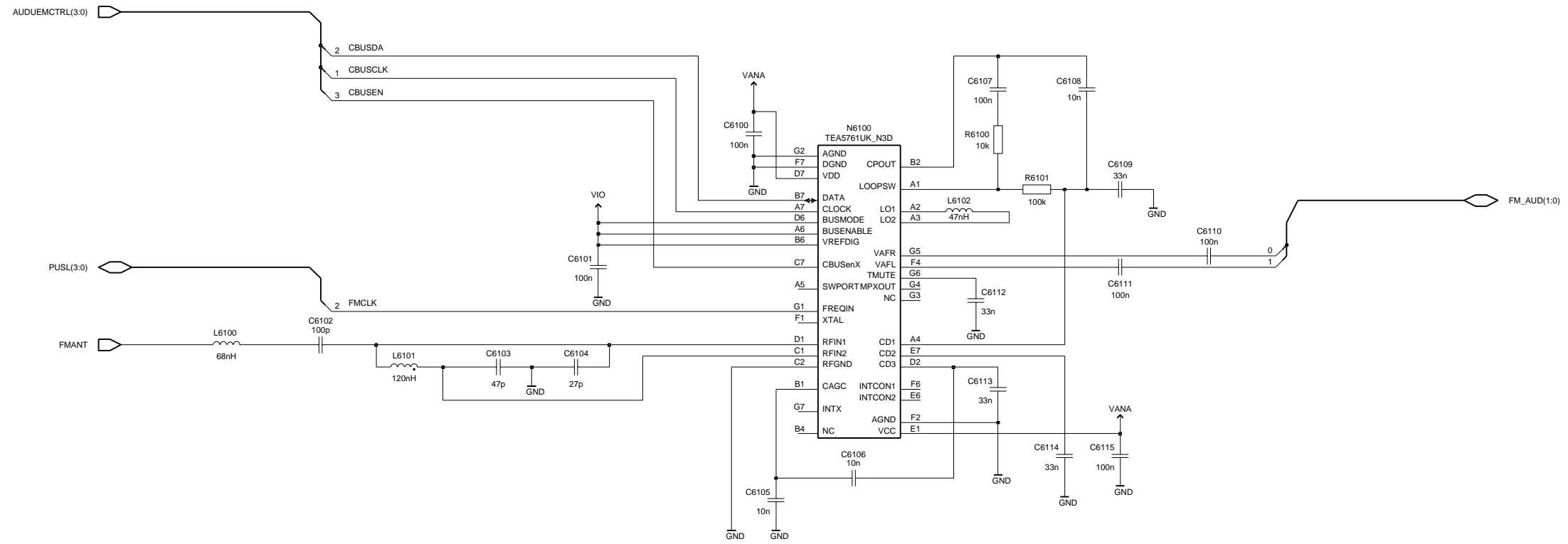

GPS Top Level

Version 7.1, edit 5

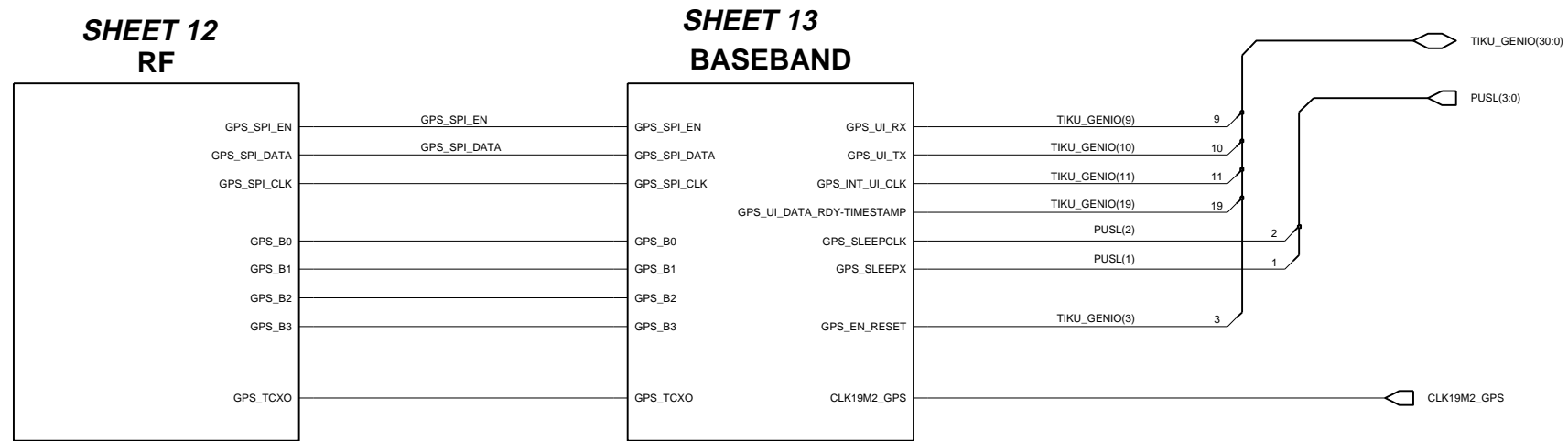

GPS RF

Version 7.1, edit 5

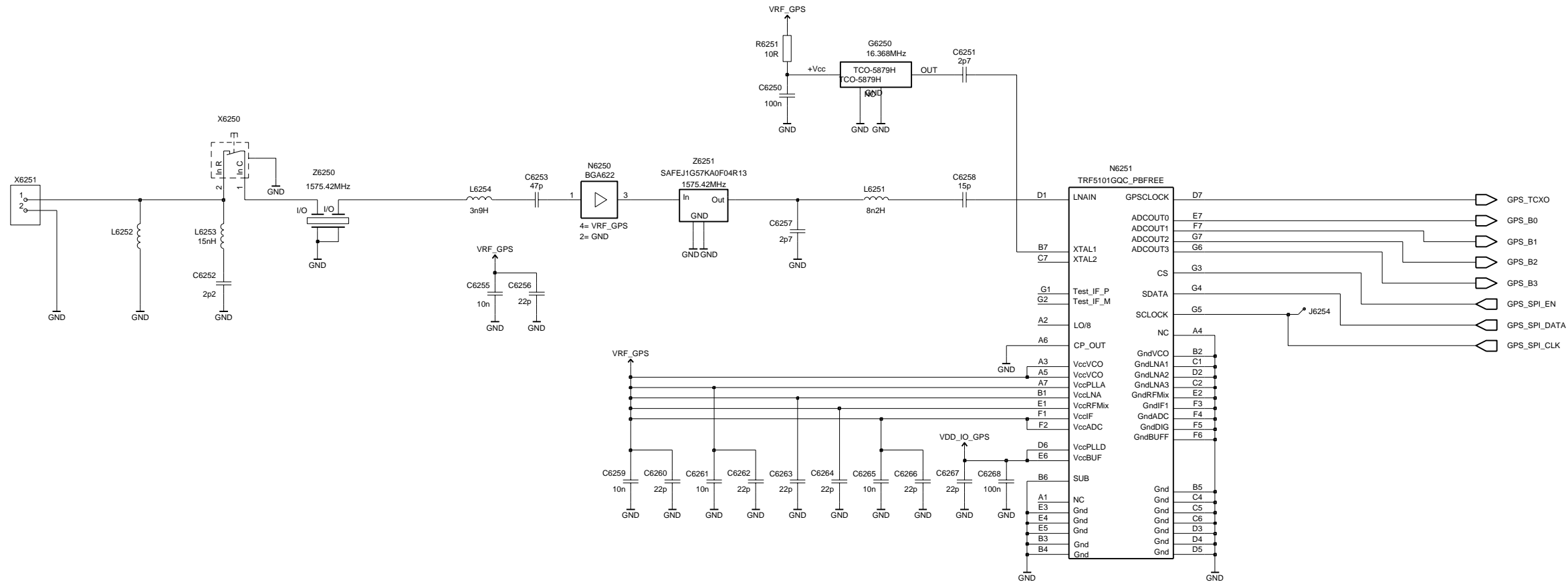

GPS BB

Version 7.1, edit 5

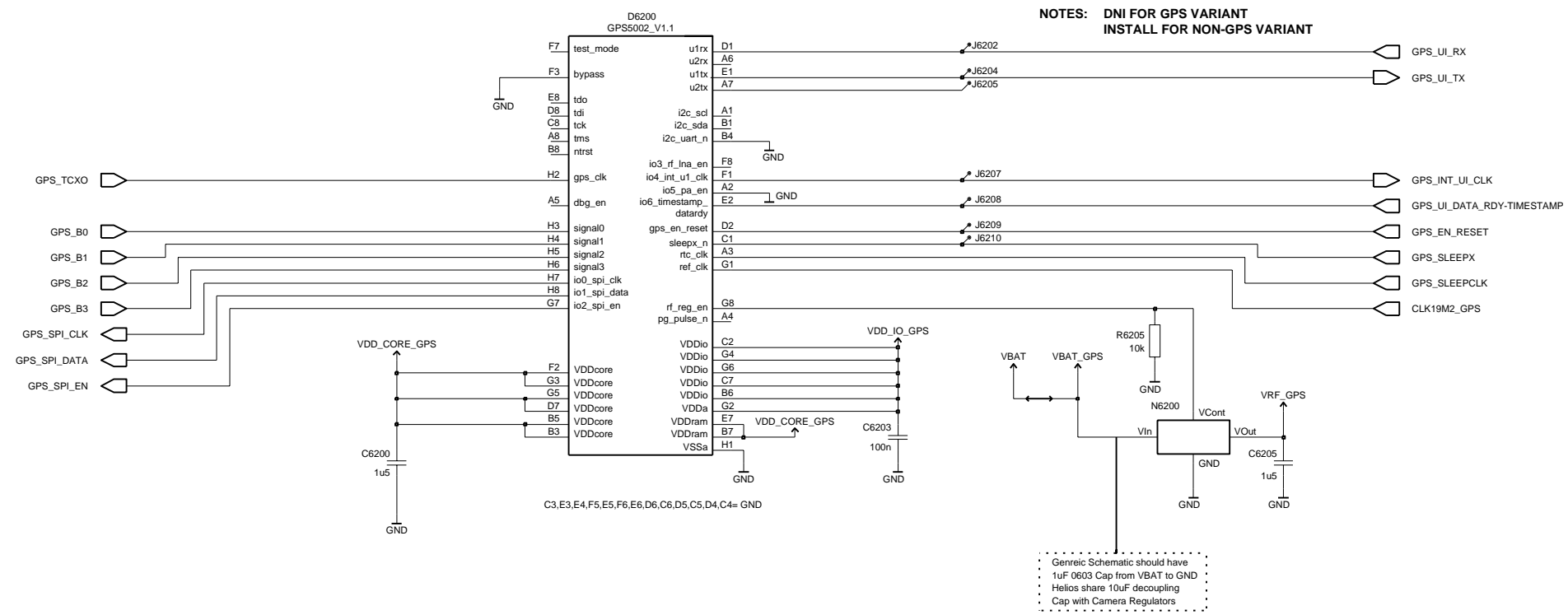

Flex Connector

Version 7.1, edit 5

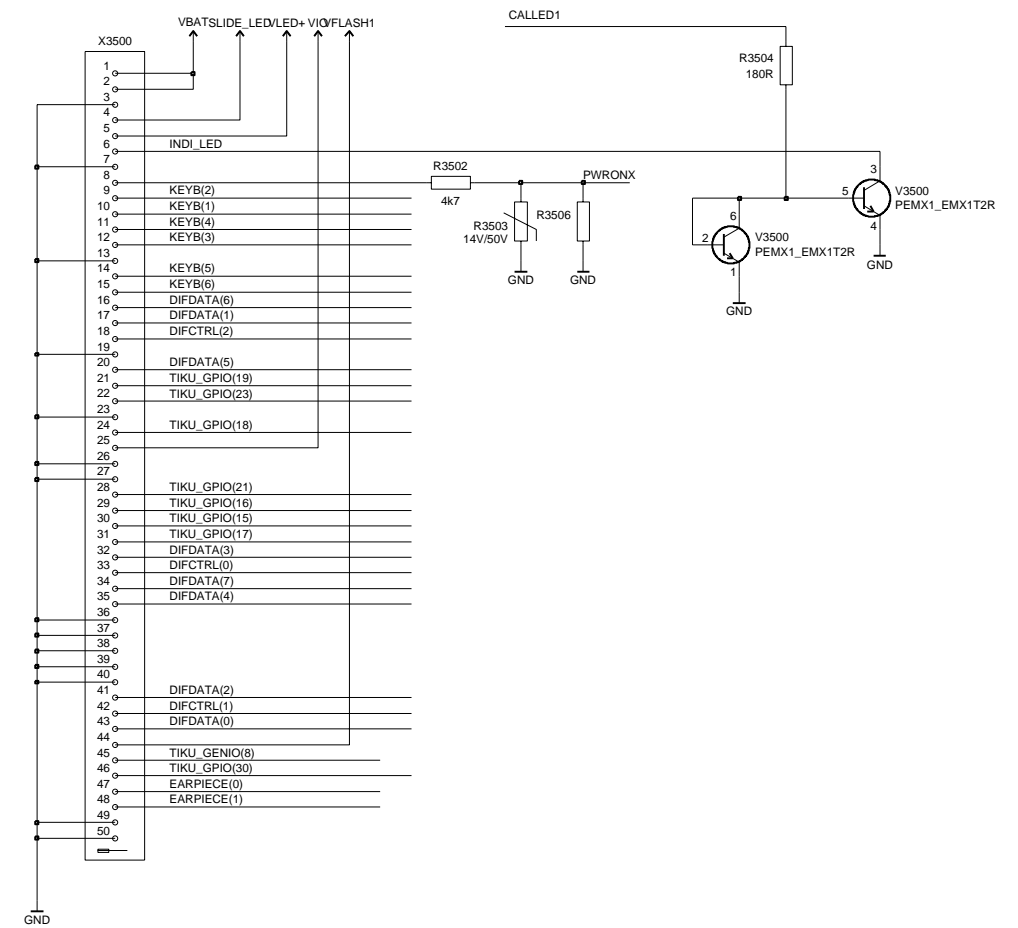
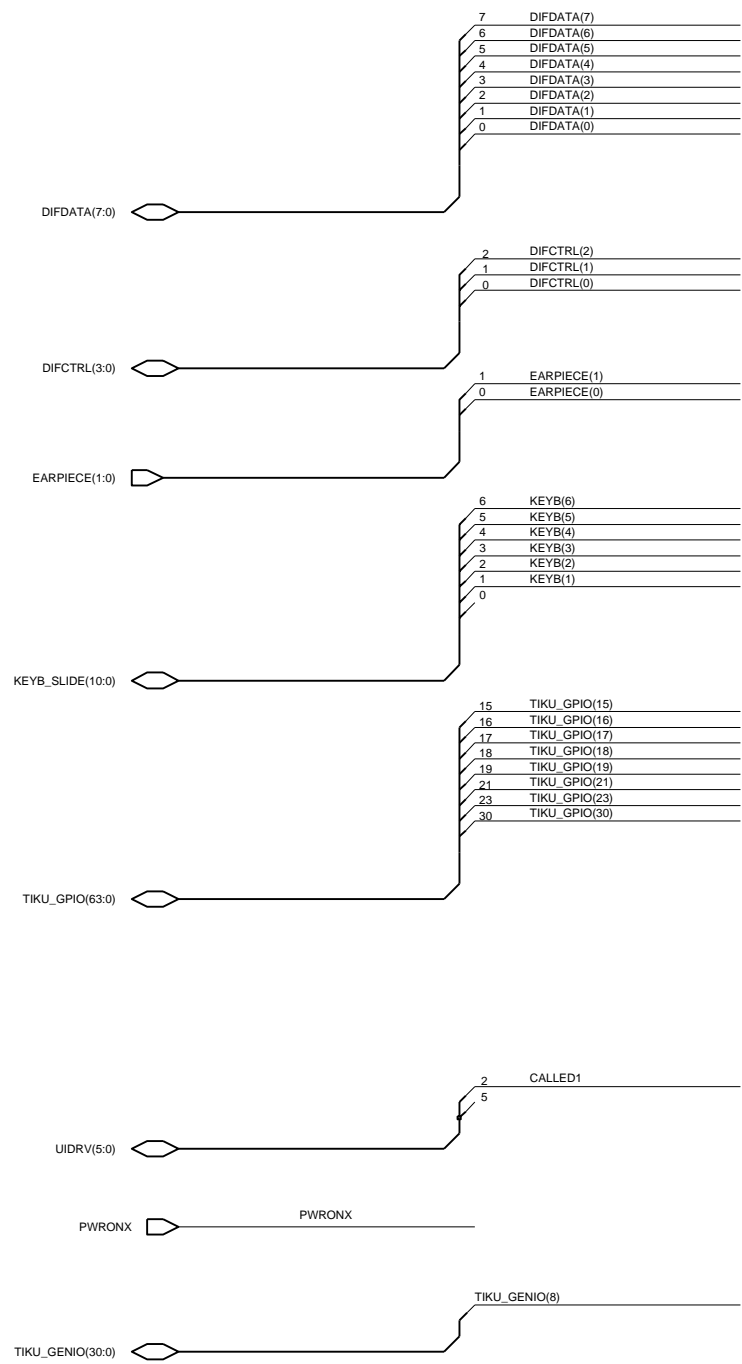

Camera and Flash

Version 7.1, edit 5

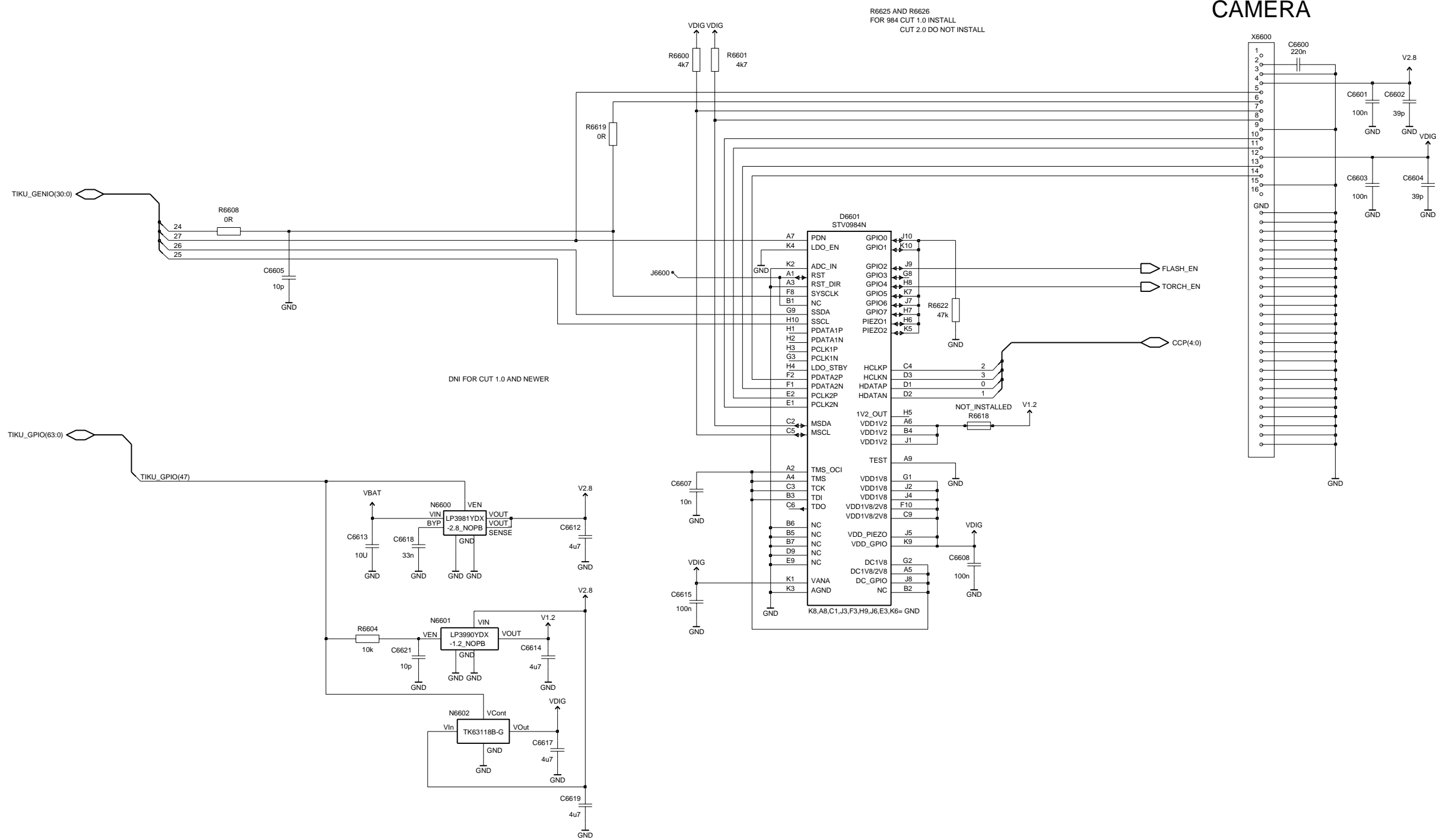

Infrared

Version 7.1, edit 5

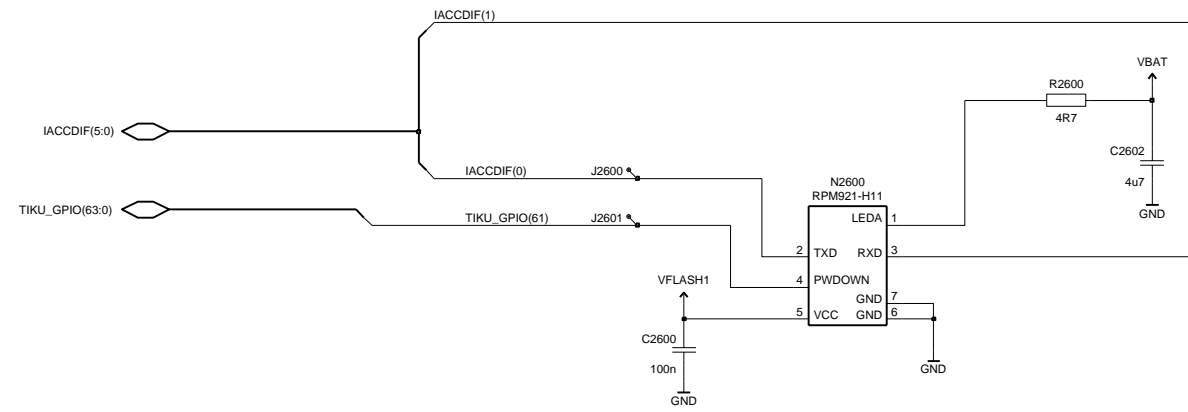

Bluetooth

Version 7.1, edit 5

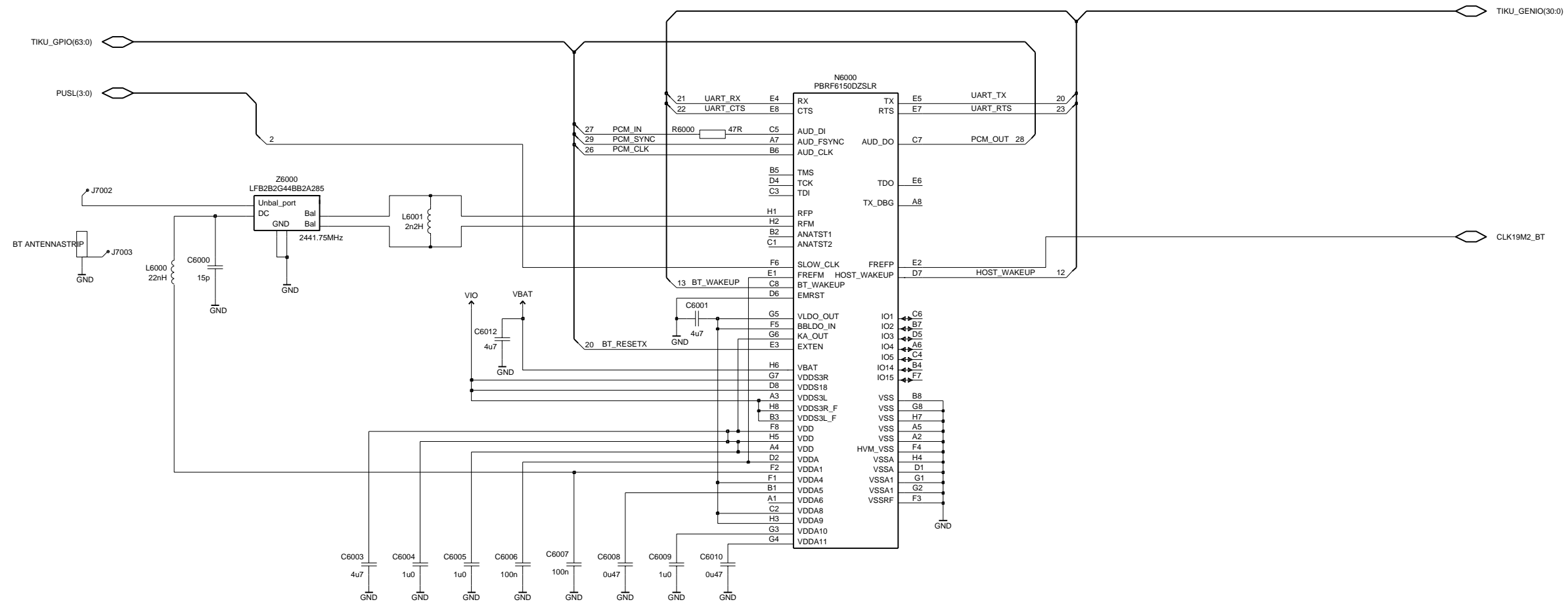

6265i Component Layout - Top

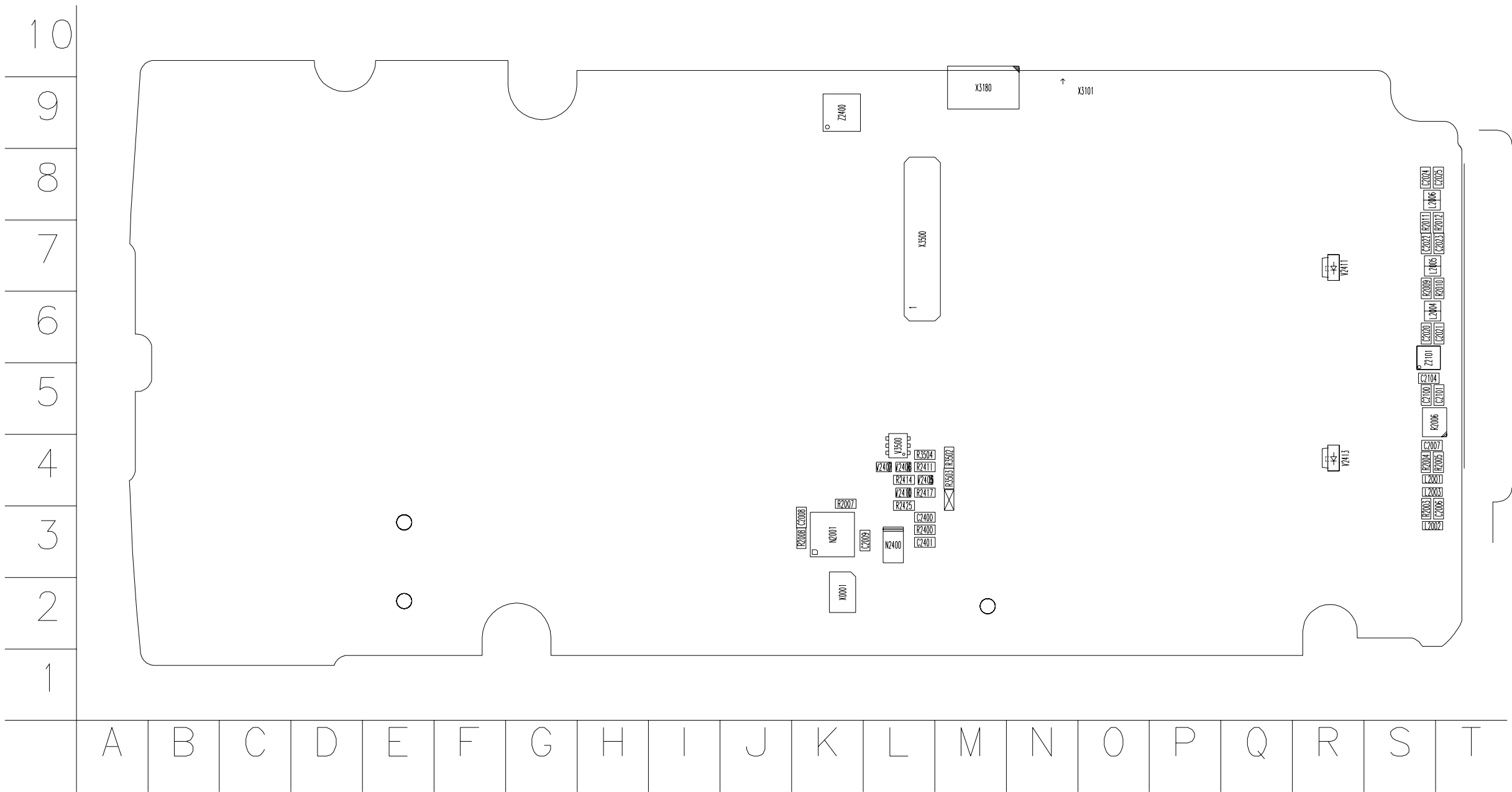

6265i Component Layout - Bottom

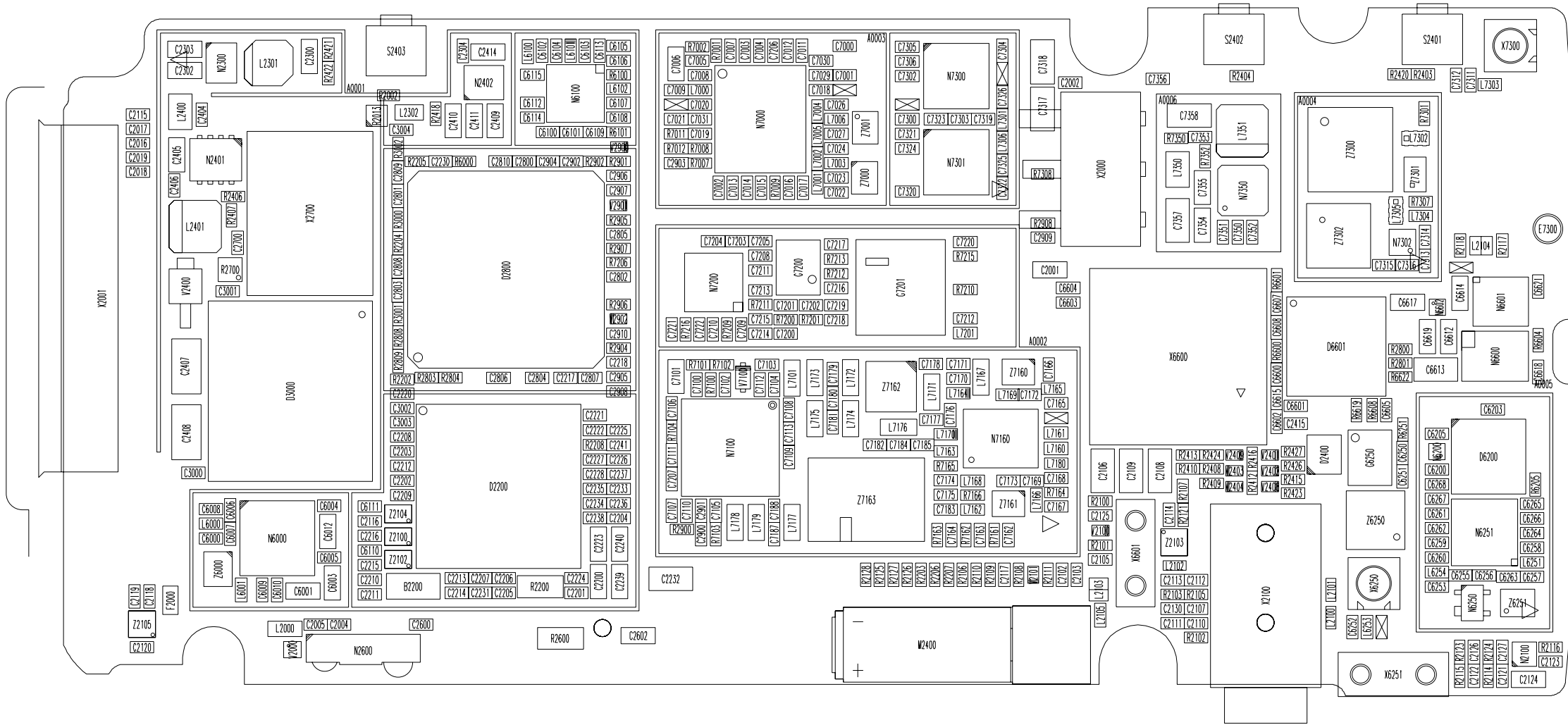

- 10
- 9
- 8
- 7
- 6
- 5
- 4
- 3
- 2
- 1

T S R Q P O N M L K J I H G F E D C B A

6265/6268 Component Layout - Top

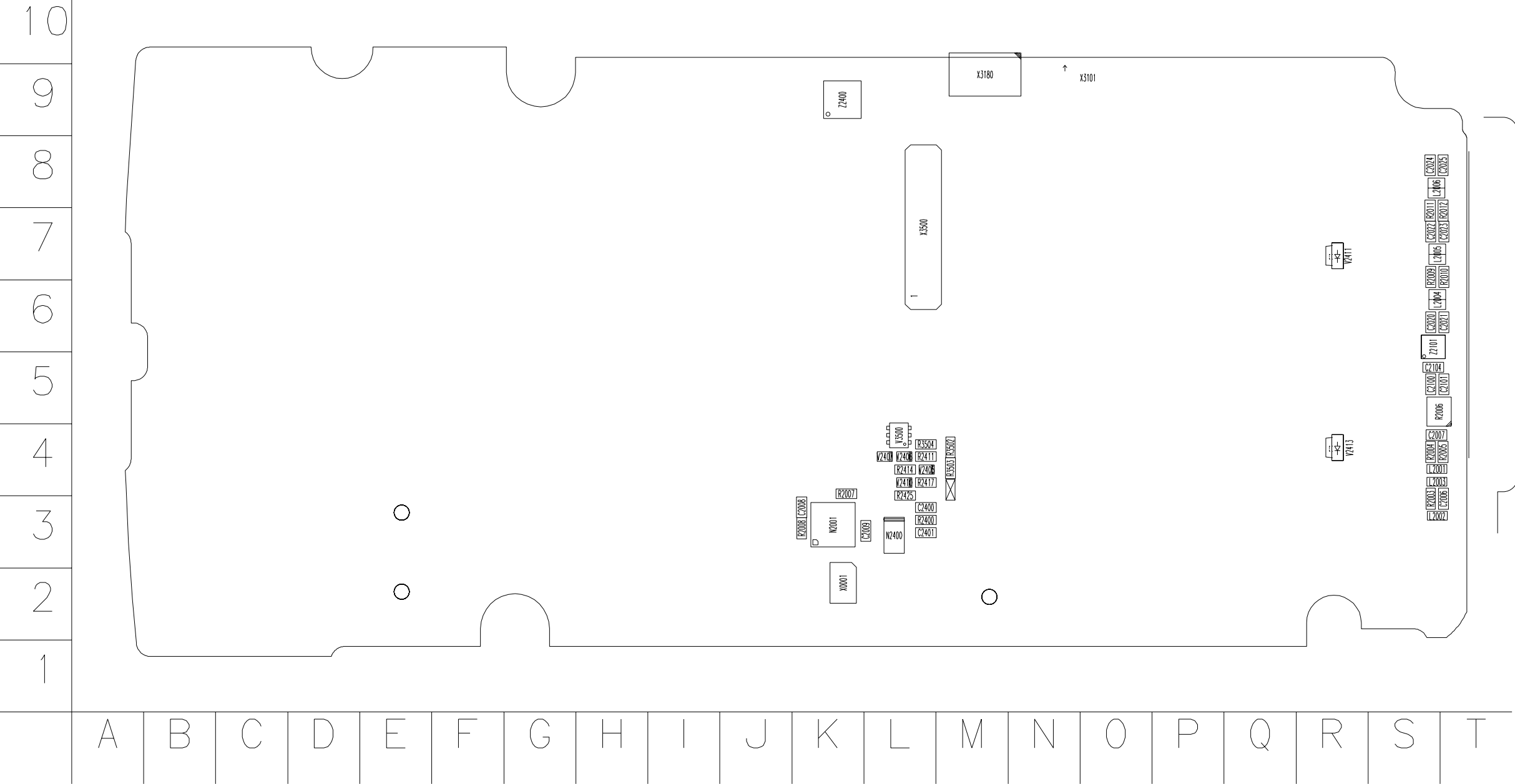

6265/6268 Component Layout - Bottom

- 10
- 9
- 8
- 7
- 6
- 5
- 4
- 3
- 2
- 1

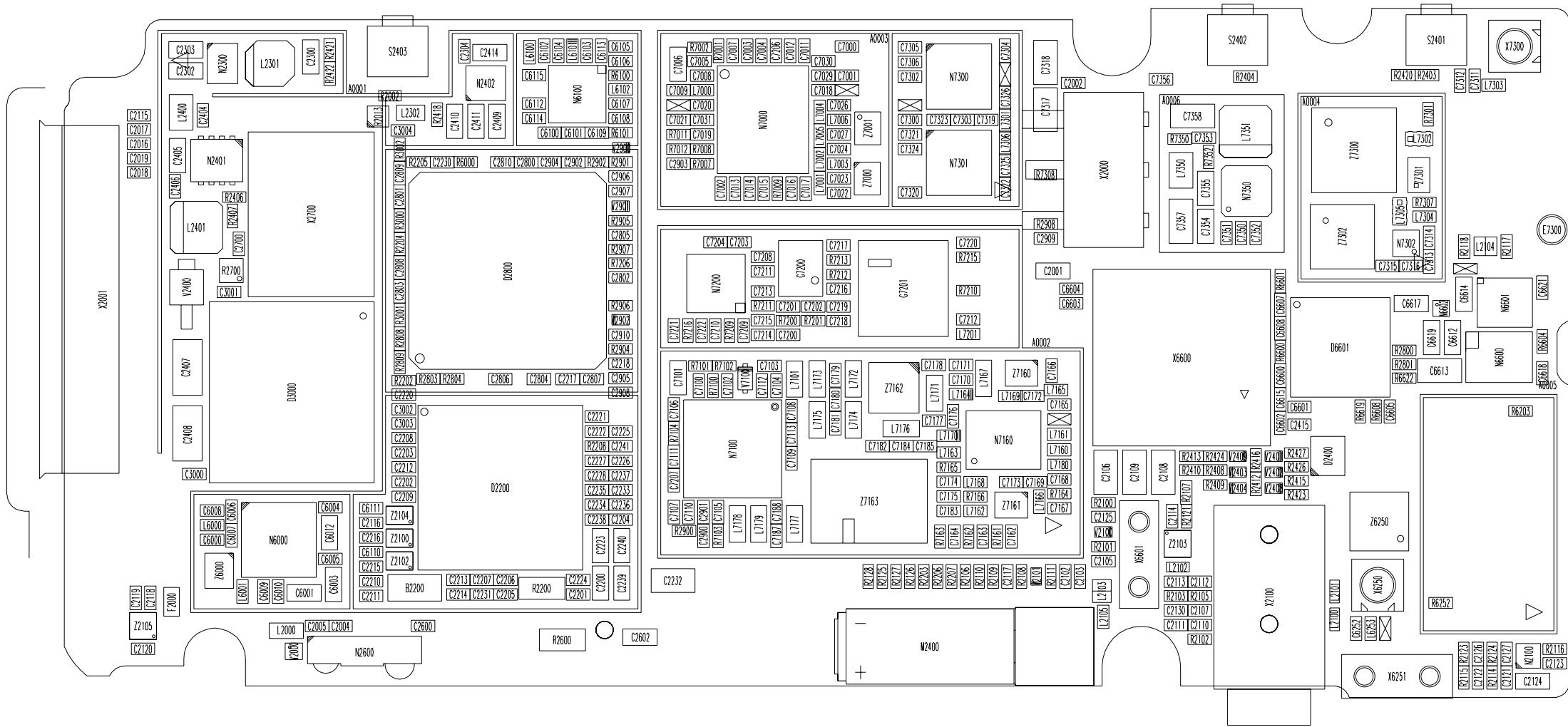

T S R Q P O N M L K J I H G F E D C B A

This page intentionally left blank.